



CL Installation Guidelines – Straight Installation



- A HOBART RECOMMENDS MINIMUM 60"** for clean table (not including rolled rim/end splash) to accommodate three racks.
- B TABLE LIMIT SWITCH** pauses operation when clean dish table is full, prolonging the life of the conveyor drive mechanism.
- C STANDARD TABLE HEIGHT 34" AFF** (per spec sheets)

- D ROOM CONSIDERATIONS**
Delivery Path (Doorways/Elevators) should have a minimum clearance of 30⁷/₈" W x 68¹/₂" H
- E DISH MACHINE TABLE TO TABLE CONNECTION DIMENSIONS**
For **CL44**, inside tank dimension is 44"
For **CL66**, inside tank dimension is 66"

Dishmachine Table Connections

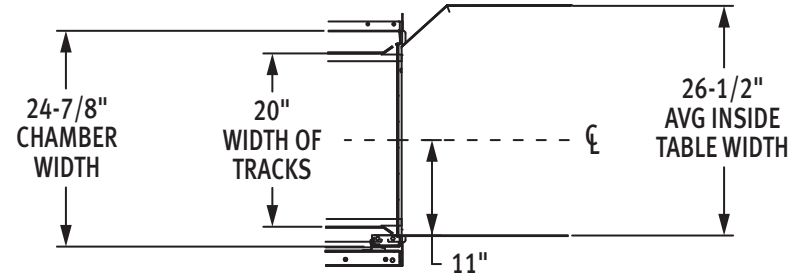

SUGGESTED TRACK AND TABLE LAYOUT

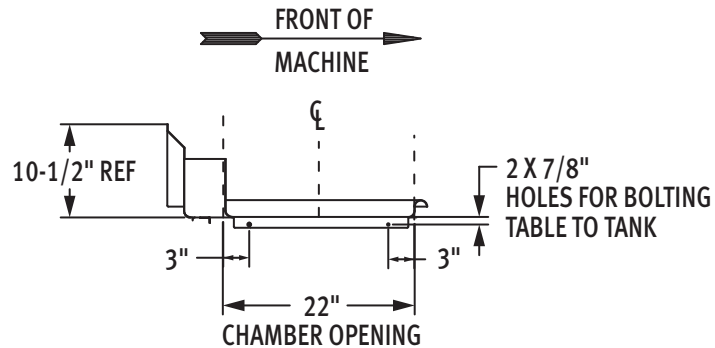

VIEW SHOWING HOLE LOCATIONS IN TURNED DOWN PORTION OF TABLE

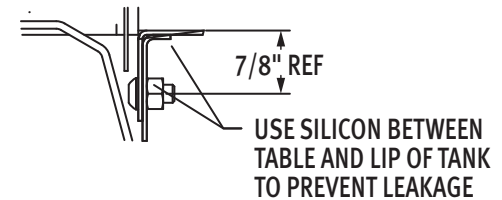

SECTIONAL VIEW SHOWING TABLE CONNECTIONS



Let's Talk

We're ready to help you optimize your dishroom operations.
Call **888-378-1338** and talk to one of our experts today.

SCAN TO FIND OUT MORE
www.hobartcorp.com/CL



HOBART

Hobart
701 S. Ridge Ave. Troy, Ohio 45373
www.hobartcorp.com

ITW FOOD EQUIPMENT GROUP
F48953 (03-24) ©2024 Hobart